

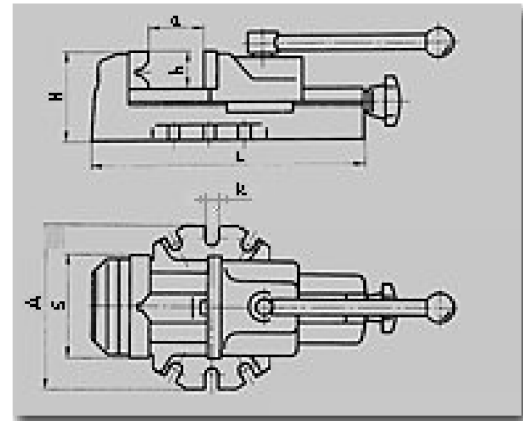

Quick - acting machine vice

◆ type 6542

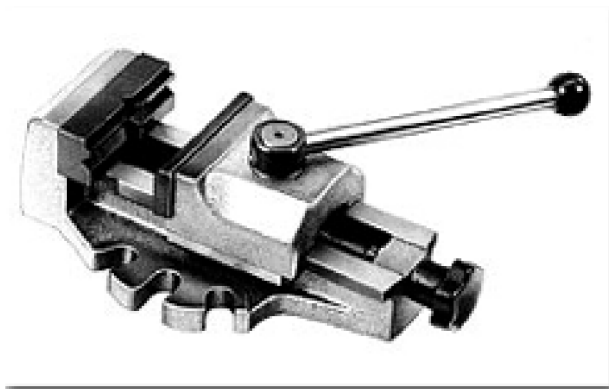

Fulfilment:

For instant setting of the workpiece - can be used for drilling and milling operations, especially for series machining. The lead screw enables the jaw spacing to be changed within the limits of 80 or 100 mm. The clamping of the workpiece is performed by a single rotary movement of the lever. The V-block is fastened to the fixed jaw, which allows to clamp bars.

- body and movable jaw are high quality castings
- V-block enables clamping flat or round workpieces vertically or horizontally
- Cam mechanism hardened and ground
- Removable jaw inserts hardened and blackened

Technical specification:

S - size	mm	80	100
A	mm	140	165
H	mm	70	80
L	mm	220	270
a max.	mm	80	100
h	mm	30	35
k	mm	14	14
Max.quick grip jaw stroke	mm	4	4
Max. clamping force daN	kN	8,0	12,0
Weight	kg	5,2	8,9